



IX100/202

Retail printing scales

The stylish IX series printing scales offer an outstanding range of features at the lowest price available.

- ◆ Most economical scale in its class.
- ◆ LCD display shows product description and enables easy programming.
- ◆ FREE PC-to-scale software included.
- ◆ Ready to weigh in minutes with simple set-up and configuration
- ◆ Flexible pre-pack, label & receipt printing from one scale.
- ◆ Network up to 9 scales.
- ◆ Easy to access, fast loading printer with take-up spool (below).
- ◆ Legal for Trade following local Weights & Measure certification.



Retail printing scales

Designed to suit small independents and convenience stores, the IX series meets the essential needs of the local retailer at the most economical price. With free PC-to-scale software and a compact footprint to suit a variety of counter sizes, it's never been easier to maintain prices, labels and COOL standards.

Features

- ◆ **Easy to read, backlit LCD display**
- ◆ **Details of up to 1000 products and prices can be stored and recalled**
- ◆ **Easy access thermal printer**
- ◆ **Wipe clean, membrane keyboard**
- ◆ **Envelope pocket for custom keyboard overlay**
- ◆ **MX020 - FREE, easy-to-use PC software to manage your scale.**
- ◆ **Network up to 9 IX scales**

Dimensions

IX100

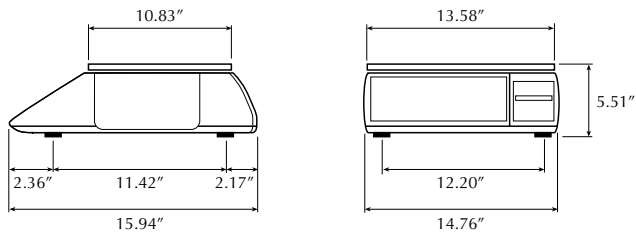

IX202

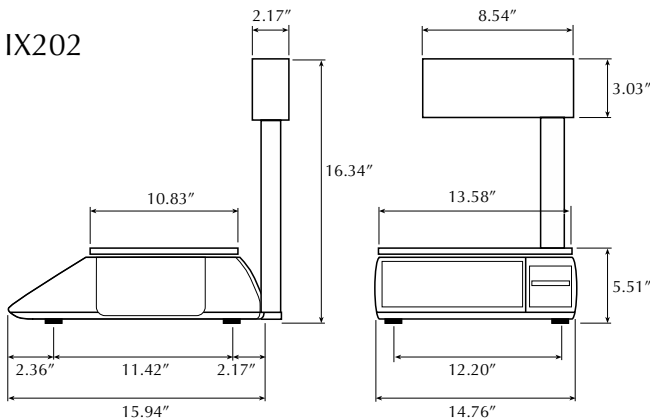

Specifications

- ◆ **Design**
IX100 – One-piece modular design.
IX202 – Customer tower display with extended keyboard.
- ◆ **Weighing Capacities Available**
15 kg x 5 g,
30 lb x 0.01 lb.
- ◆ **Display**
Backlit LCD displays
- ◆ **Printer**
Easy-access, thermal label and receipt printer with take-up spool for backing paper:
2.2 in/second print speed.
3.94 in/100 mm diameter roll.
2.2 in/56 mm print width.
- ◆ **Keyboard**
Wipe clean keyboard with audible beep.
Fast number entry via cluster key arrangement.
Envelope pocket for keyboard overlay.
IX100 – 57 key keyboard. 34 direct PLUs.
IX202 – 79 key keyboard. 56 direct PLUs.
- ◆ **Data Memory**
Details of 1000 products/prices can be stored and recalled.
- ◆ **Operators**
Up to eight operators can serve customers from any of the scales on the network.
- ◆ **Barcodes**
EAN 8/EAN 13/UPC 12/UPC 13
- ◆ **Interfaces**
RS485 scale interface as standard. Nine scales may be linked in a network.
RS232 link to PC or barcode scanner.
Cash drawer interface.
- ◆ **Management Reports**
PLU, group and operator totals.

© Avery Weigh-Tronix, LLC 2006. All rights reserved. This publication is issued to provide outline information only which, unless agreed by Avery Weigh-Tronix in writing, may not be regarded as a representation relating to the products or services concerned. Avery Weigh-Tronix reserves the right to alter without notice the specification, design, price or conditions of supply of any product or service.

Avery Weigh-Tronix
(Retail North America)
1000 Armstrong Drive, Fairmont, MN 56031

PH Toll-Free: 800-237-1886
PH: 507-238-4461
FAX Toll-Free: 800-237-2063
FAX: 507-238-8756

E-mail: sales@AveryBerkelUSA.com
Internet: www.AveryBerkelUSA.com

Avery Weigh-Tronix

